

BC6-7Ah 6V7Ah

Valve Regulated Lead Acid Battery



Specifications

Nominal voltage	6V (3 cells per unit)	
Rated capacity (20HR)	7Ah/5.25V	
Dimensions	Length	151±1.5mm (5.94inch)
	Width	34±1mm (1.34inch)
	Height	94±1mm (3.70inch)
	Total height	100±1mm (3.94inch)
Approx. weight	1.10kg (2.42lbs)±5%	

Outer dimensions (mm)

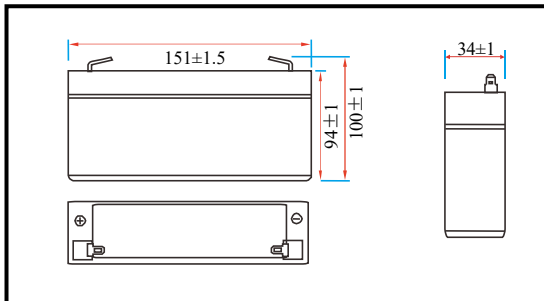

Terminal type (mm)

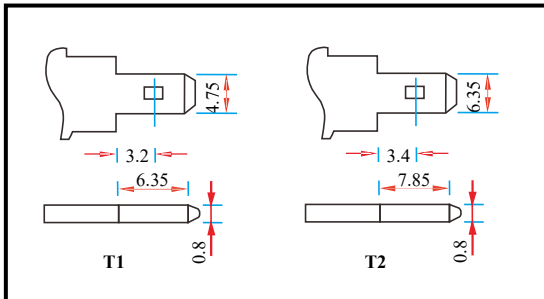

Construction

Component	Positive plate	Negative plate	Container	Cover	Separator	Electrolyte	Safety valve	Terminal
Raw material	Lead dioxide	Lead	ABS	ABS	AGM	Sulfuric acid	Rubber	Copper

Constant current discharge characteristics unit: Ampere/Block (at 25°C, 77°F)

F.V/Time	5min	10min	15min	30min	60min	2h	3h	4h	5h	10h	20h
4.80V	26.7	16.9	13.2	7.46	4.59	2.51	1.74	1.44	1.22	0.66	0.36
4.95V	25.9	16.4	12.9	7.31	4.52	2.49	1.72	1.43	1.21	0.66	0.35
5.10V	24.9	15.8	12.4	7.08	4.40	2.47	1.71	1.42	1.21	0.66	0.35
5.25V	23.8	15.1	12.0	6.91	4.31	2.43	1.70	1.41	1.20	0.65	0.35
5.40V	22.5	14.2	11.4	6.66	4.18	2.37	1.65	1.36	1.16	0.64	0.34

Constant power discharge characteristics unit: Watt/Block (at 25°C, 77°F)

F.V/Time	5min	10min	15min	30min	60min	2h	3h	4h	5h	10h	20h
4.80V	149	95.5	75.4	42.7	26.5	14.7	10.3	8.55	7.29	3.98	2.13
4.95V	145	92.7	73.6	41.9	26.1	14.6	10.2	8.50	7.25	3.96	2.12
5.10V	139	88.9	70.9	40.6	25.5	14.5	10.2	8.44	7.20	3.94	2.11
5.25V	133	85.0	68.5	39.6	25.0	14.2	10.1	8.38	7.15	3.92	2.10
5.40V	125	80.3	64.9	38.1	24.2	13.9	9.8	8.13	6.93	3.84	2.06

Note 1: Above characteristics data can be obtained within three charge and discharge cycles.

Characteristics

Capacity (25°C)	20HR (5.25V)	7Ah
	10HR (5.25V)	6.5Ah
	1HR (4.80V)	4.2Ah
Terminal type		T1/T2
Internal resistance (Fully charged, 25°C)		Approx. 16mΩ
Capacity affected by temperature (10HR)	40°C	102%
	25°C	100%
	0°C	85%
	-15°C	65%
Self-discharge (25°C)	3 months	Remaining capacity: 91%
	6 months	Remaining capacity: 82%
	12 months	Remaining capacity: 65%
Nominal operating temperature		25°C±3°C (77°F±5°F)
Operating temperature range	Discharge	-15°C~50°C (5°F~122°F)
	Charge	-10°C~50°C (14°F~122°F)
	Storage	-20°C~50°C (-4°F~122°F)
Float charging voltage (25°C)		6.80 to 6.90V Temperature compensation: -9mV/°C/Block
Cyclic charging voltage (25°C)		7.25 to 7.50V Temperature compensation: -15mV/°C/Block
Maximum charging current		2.1A
Maximum discharge current		105A (5 sec.)
Design life	5 years for floating (25°C)	
	Eurobat (20°C): 3-5 years, standard commercial.	

● Discharge characteristics (25°C)

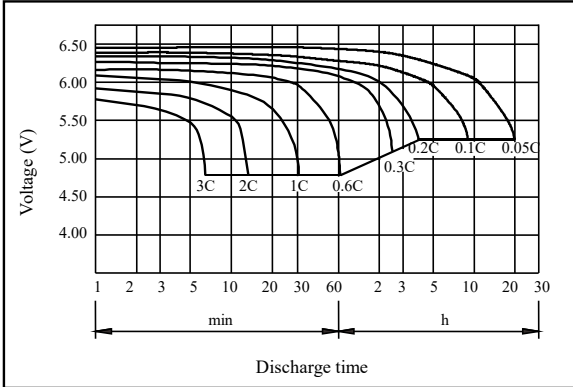

● Charging characteristics (25°C)

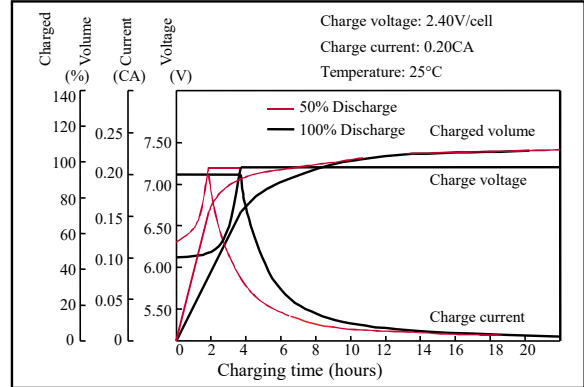

● Temperature effects on capacity

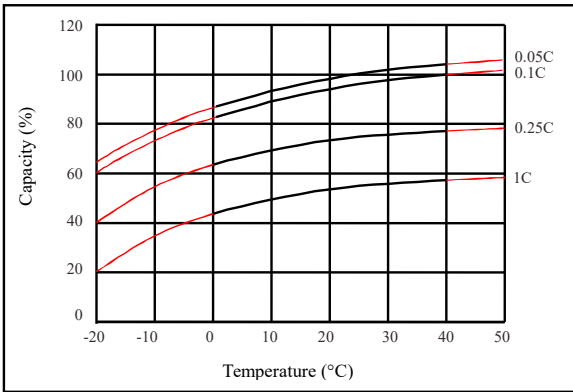

● Self-discharge characteristics

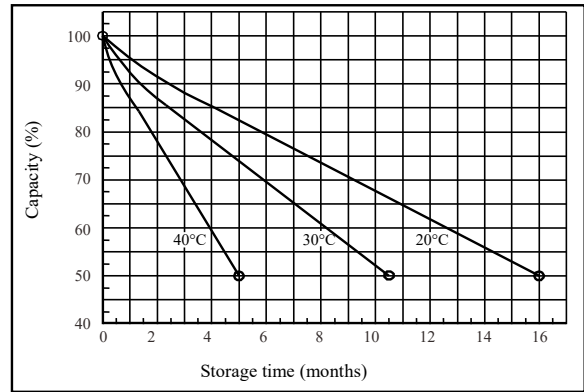

● Floating life on temperature

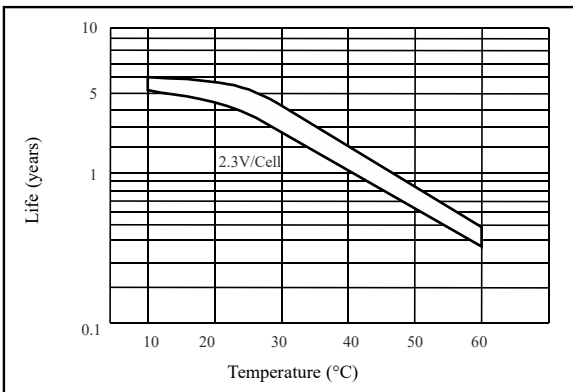

● Cycle life on D.O.D (25°C)

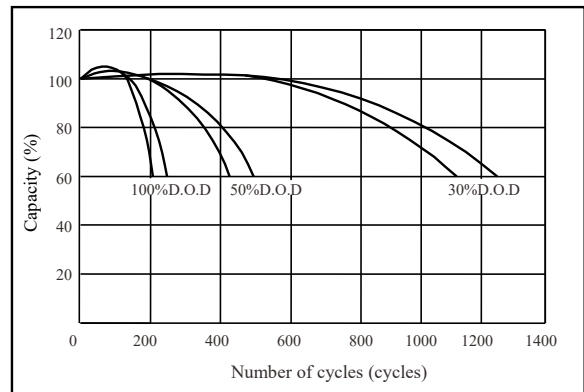

● Relationship for OCV and capacity (25°C)

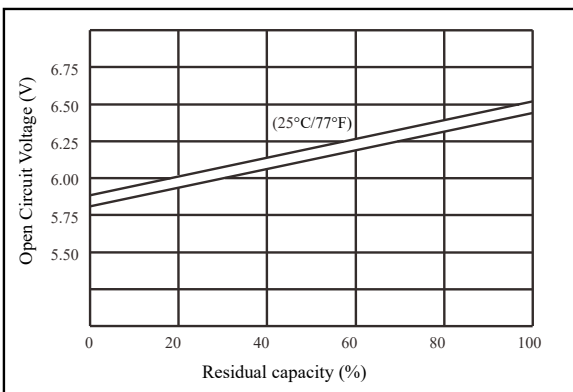

● Relationship for charging voltage and temperature

